

CATALOGUE

BANIDES

BRASS VALVE & FITTING PE VALVE EXCESS FLOW VALVE
RACCORD & ROBINET LAITON VANNE POLYÉTHYLÈNE DISPOSITIF DE SÉCURITÉ
CONEXIÓN Y VÁLVULA DE LATÓN VÁLVULA DE POLIÉTILENO VÁLVULA DE EXCESO DE FLUJO

BRASS VALVE & FITTING
PE VALVE
EXCESS FLOW VALVE

GAS & WATER NETWORK
RÉSEAU GAZ & EAU
RED DE GAS Y AGUA

GAS & WATER NETWORK

The world of Banides

Push button safety valve

page 29



PE Valve with branch saddle

page 16



PE Water connection kit

page 12

PE Gas valve

page 10

PE Water Valve

page 10

**PERRSO® PE/PE
connector**
page 25

**PE valves with
purge points**
page 14



**BD STOP
excess flow
valve**
page 21



**DPBE: Retrofit
excess flow valve**
page 22



PERRSO® cap
page 25

TECHNICAL MANUAL
page 33

Introduction

Designing and manufacturing valves, fittings, connections and safety products for gas and water installations since 1928, **BANIDES** is a family business that has become a major player in France, Europe and the rest of the world.

On the French market, **BANIDES** does work on either side of the meter, making it the undisputed leader among professionals in the sector.

On the international market, **BANIDES** has positioned itself on the network, specialising in polyethylene valves from dn20 to dn315, as well as excess flow valves (such as flow-sensing releases) and brass products.

Its head office and production site are at Le Tréport in France (2 hours from Paris). This concentration of knowledge and production resources enables us to control the entire manufacturing chain (PE and metal products). With the renewal of our machinery, the modernisation of our equipment and the automation of our production lines (cobots, robots, multi-axis machines, latest-generation electric presses),

BANIDES has embarked on a relocation strategy since 2018 in order to guarantee a high level of service to its customers, producing more than 75% of its range at the original site. What's more, the presence of a major French port less than 2 hours away also gives us great flexibility in transporting our products around the world.

With over 95 years' experience in the design and manufacture of valves and fittings, we are continuing to develop our products and production processes for you, and are also extending their areas of application, which were historically in gas, but also for over 20 years in water.

Our experience and our successes are the fruit of a collective effort based on know-how that has been passed down from generation to generation within our teams.

Alex DEBEAURAIN
President

A company present all over the world

For over 40 years, driven by its ambitions and its desire to develop its activities, **BANIDES** has been very active internationally, and is represented by an export team.

BANIDES also relies on its network of specialist agents and distributors, as well as its sales subsidiary based in Algiers.

Our sales force enables us to be present in more than 30 countries and to conquer new markets.

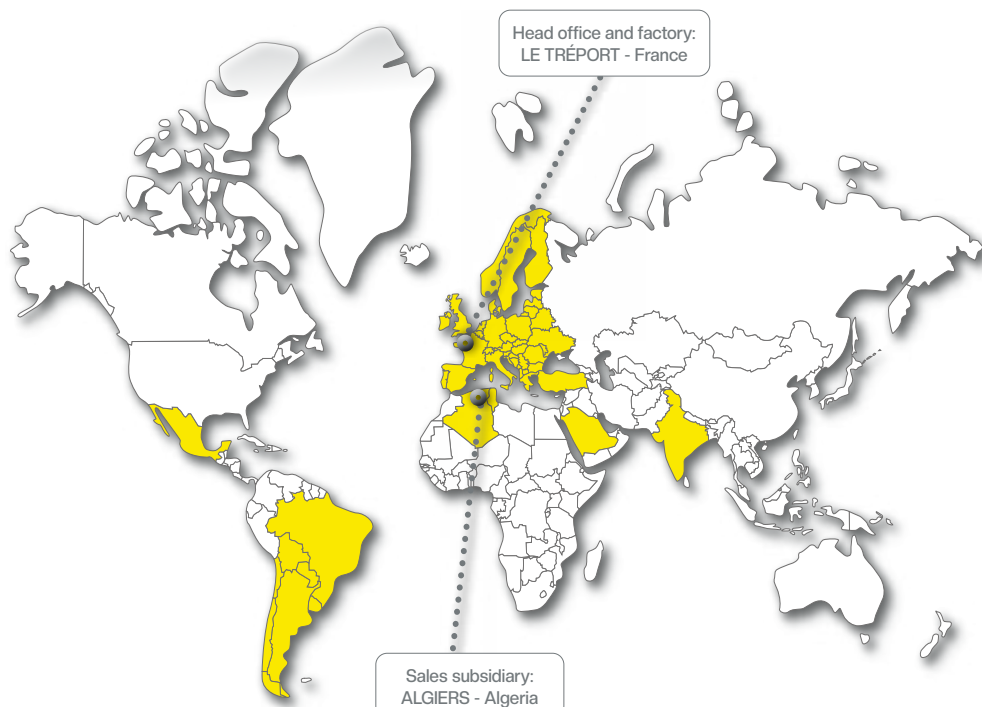

Our story

The result of a partnership between two individuals, Lucien BANIDES and Jacques DEBEAURAIN, **BANIDES** started out as a copper and bronze foundry specialising in traditional metal gas fittings. It opened up to international markets in the 1980s.

As soon as he joined the company in 1984, Jean-Luc DEBEAURAIN diversified the business into plastic

fittings, excess flow valves, quick and easy connection systems and then into butane/propane products.

Since then, thanks to the excellence of the people who have made up its teams, **BANIDES** has continued to adapt and modernise to become a key player in the gas industry.

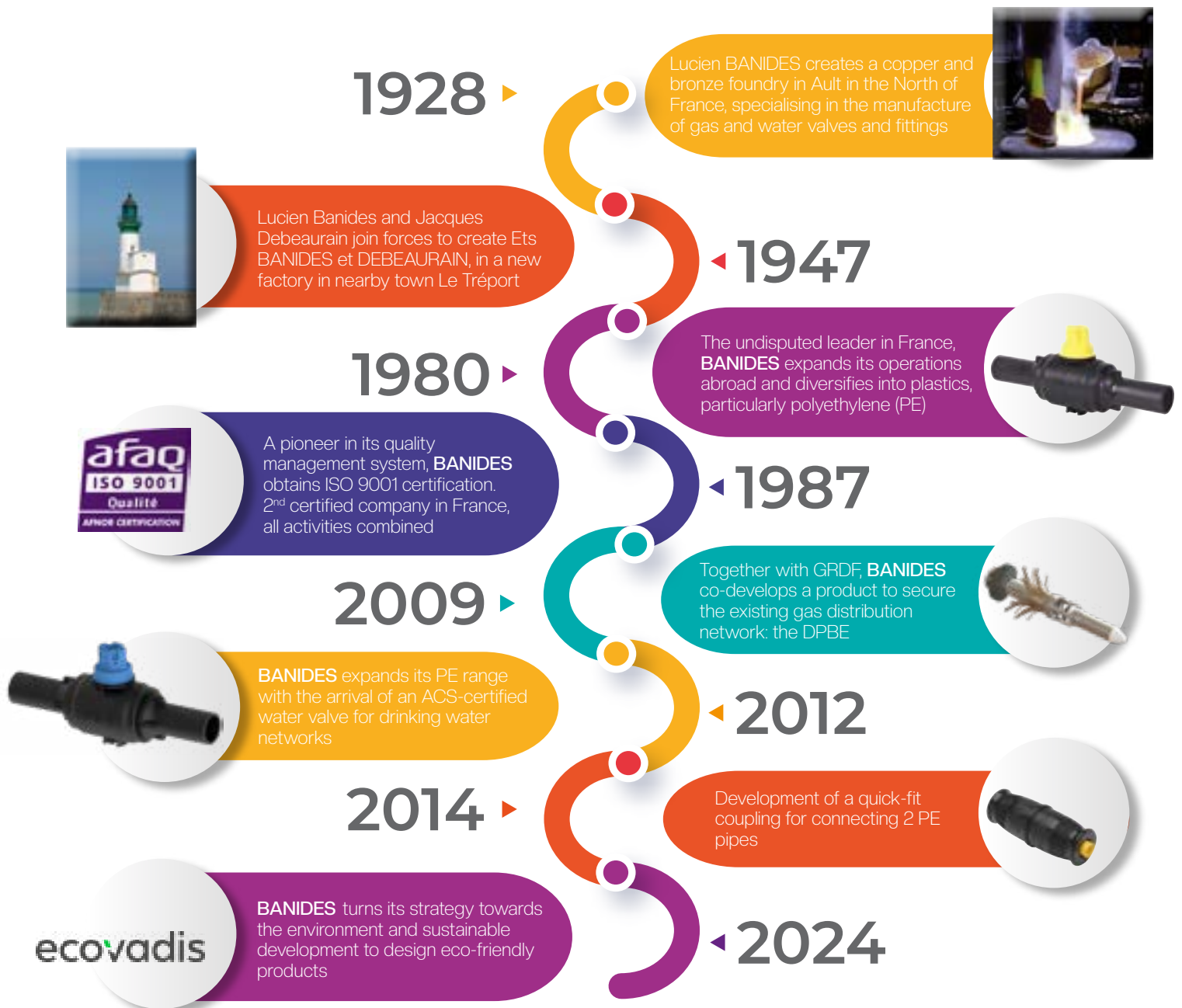

Our quality and CSR policy



At **BANIDES** we're committed to making quality products, but that's not all.

Our aim is to make our products in a more ecologically responsible way throughout the manufacturing process, but also to provide and offer all our teams a pleasant, fair and rewarding working environment.

BANIDES is first and foremost a human-scale business where life is good, and where commitment and modelling excellence are values shared by all.

For the customer, it also means a strong technical and sales team, comprising a design office specialising in the development of a product to meet a particular challenge, and an exclusive field sales department, supported and accompanied on a daily basis by a specialised customer service team that is always available and ready to listen.

This entire team will guide you towards the best decisions and technical choices throughout the various stages of your project.



Industrially speaking, choosing **BANIDES** is to benefit from our solid experience in the mastery of metallic and plastic materials (brass, copper, steel, polyethylene), their assembly (valves and fittings), excess flow valves (DPBE, BD STOP), flexible hose technologies, PLT and connections.



Every day, we ensure that our processes, which have been ISO 9001 certified for over 30 years, are followed properly and run smoothly. Our certifications are the culmination of a long process of implementing quality standards. Their aim is to constantly improve product quality. What's more, we have a fully integrated manufacturing unit and an in-house test laboratory with NF certification from Certigaz AFNOR. This enables us to carry out fully autonomous tests, with results that are recognised under NF certification.

We are proud and privileged to be able to use the full range of advanced control tools (spectrometry, 3D printing, MFR, hydrostatic tank, climatic chambers) to serve our customers. All this means that we have to master the regulatory and standards environment in order to offer products that combine safety, ease of installation and maintenance, and durability.



BANIDES is stepping up its CSR policy and seeking to reduce its environmental impact. As part of its QSE (Quality - Safety - Environment) policy,

BANIDES has made environmental issues one of the pillars of its development strategy.

The company's development takes into account managing the risk of water and soil pollution related to its activities, water and energy consumption, waste production and the recycling process.

BANIDES is taking a number of steps to reduce its environmental footprint, including waste sorting, oil reprocessing, shredding and recycling its plastic waste, adaptive lighting, modernising and managing its heating through a BMS, recycled cardboard, conservation grazing, etc. An industrial and regional ecology initiative has been launched with the local government to join forces on energy issues and waste management.

What's more, we place our employees at the heart of our environmental project. We want to guarantee a healthy, safe and positive working environment. **BANIDES** aims to maintain work/life balance. We remind everyone of their right to disconnect outside working hours.

We educate our staff and team leaders about habits and postures to reduce occupational risks. We involve all our employees in a health and safety management system at work, which includes a review of the car park circulation plan and pedestrian circulation, as well as a new evacuation plan integrating floor wardens and priority evacuation for certain individuals.



In order to comply with and apply the laws and regulations in force, **BANIDES** has defined ethical principles to mark its commitment to integrity, rejection of all forms of corruption and standing against conflicts of interest.

In this context, **BANIDES** has decided to strengthen its gifts and entertainment policy in line with the recommendations made by the French Anti-Corruption Agency (AFA) in its 2020 Practical Guide. This policy sets out the rules applicable to gifts and invitations received and offered.

We have a number of plans for the coming years, including engaging our suppliers through awareness-raising initiatives and signing a responsible purchasing charter.

We also plan to carry out a full carbon assessment to improve the rating of our products, to increase the proportion of recycled materials in the PE and brass manufacturing process without altering the quality of our products, and even to install charging points for electric cars.

***Our projects are many
and our ambitions are realistic.***

ecovadis

PE VALVES

 Water Valve 5060	10
 Gas Valve 5030	10
PE valves with purge points	14
J5530 valve with sealed protection sleeve	15
PE valve with branch saddle	16

EXCESS FLOW VALVES

BDSTOP	21
DPBE	22

CONNECTION AND TRANSITION

PERRSO PE/PE quick connector	25
PE/Metal fitting	26

BRASS VALVE

Safety valve	29
Meter valve - Heating system valve	31
Valve for interior installation - Integrated automatic shut-off valve	32

TECHNICAL MANUAL

Pressure conversion table	34
Matching tubes	34
Threading and sealing	35
Gas thread compatibility	36
Seals	37

Meanings of symbols and standards to which our products conform:

	Natural gas or LPG network.		Certification of compliance with the certification rules for the NF mark
	Bottled butane/propane gas		Certifies that the product complies with all the requirements laid down by European Union legislation
	Individual housing		Made in France
	Collective housing		BSI Kitemark certified product
	ERP & industry		Health compliance certificate



Polyethylene valve

Polyethylene valve

With over 30 years' experience in plastic injection moulding, **BANIDES** has developed a wide range of PE ball valves, from dn20 to dn315, using PE100/PE100-RC as the raw material. The gas-tightness of **BANIDES** PE ball valves is ensured by one-piece elastomer seals. We recommend using electrofusion welding to connect the PE ball valve to the gas pipe. The double-length PE sleeves allow up to 2 welds. The sleeves are protected from external contamination (dust, etc.) by a protective cap.

Why choose **BANIDES** valves?



Unrivalled technical performance

- 1/4 turn ball valve
- 100% virgin resin (50-year operating life)
- PE100/PE100-RC: Black high-density polyethylene (EN 1555-1 compliant)
- Temperature resistance: -20°C/+40°C (Gas), 0°/+60° (Water)
- Low operating torque
- Low and medium pressure valve up to 10 bar / MOP 10
- Bi-directional valve: flow in either direction
- Valve to be welded using electrofusion (NB: butt fusion only if resin compatibility between valve and pipe or fitting).

A unique valve design

- External tightness against water, dust, sand and alluviums.
- Internal valve design that reduces pressure drop (optimum shape)
- Numerous accessories available (baseplates, T-saddles, extensions, etc.)
- Significant guard angle (8° minimum) = maximum safety in closed position
- No maintenance required
- Easy fitting of all standard extensions on the stem square (internal or external attachment)

A modern industrial tool

- Automated production and final testing for perfect control of valve tightness
- In-house laboratory accredited by a third-party organisation (NF certified)
- Packaging tailored to customer needs
- ISO 9001 certified company



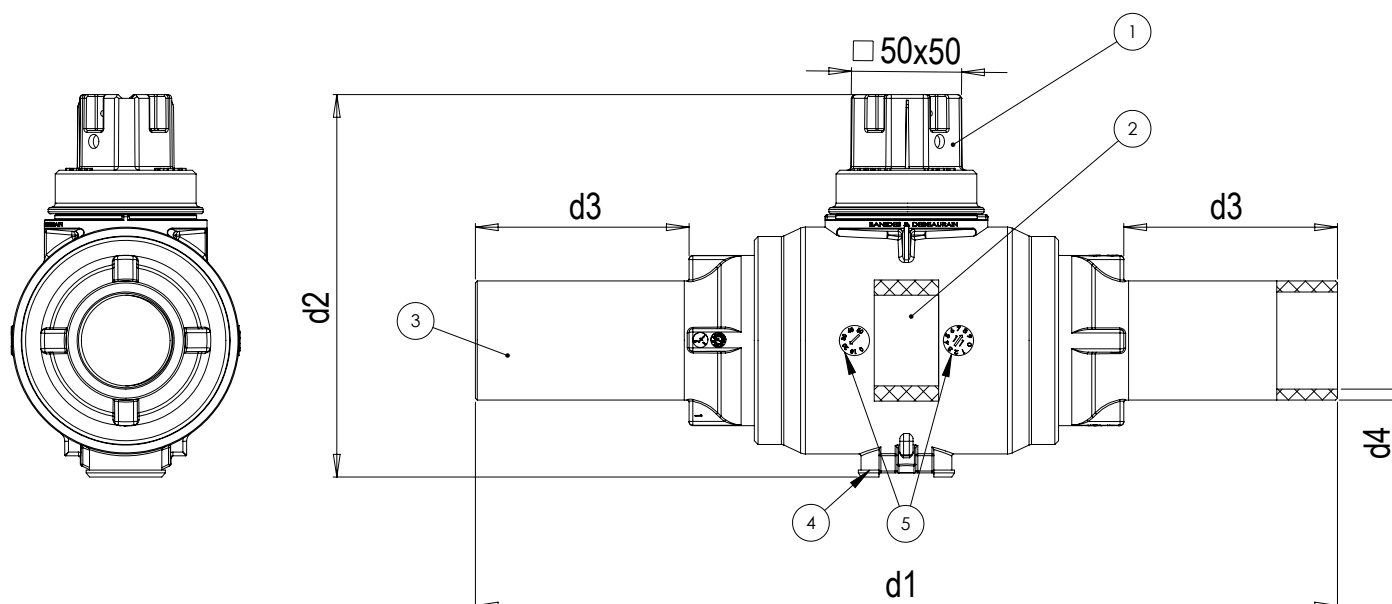

List of components

1	operating square head
2	ball
3	sleeve
4	clips for baseplate
5	traceability data

Full-bore

Ref GAS	Ref WATER	Outside Ø PE	Size	d1	d2	d3	d4 SDR11	d4 SDR17/17.6	Weight (kg)
05030020	05060020	20	15	323	148	87	3.0		0.8
05030025	05060025	25	20	323	148	87	3.0		0.8
05030032	05060032	32	25	323	148	87	3.0		0.8
05030041	05060041	40	32	456	204	112	3.7		2
05030050	05060050	50	40	447	204	90	4.6		2.2
	05060063	63	50	456	203	110	5.8		2.3
05030067		63	50	383	167	112	5.8		1.1
05030091	05060091	90	80	463	252	114	8.2	5.4	4.3
05030111		110	100	499	252	129	10.0		4.5
05030127	05060127	125	125	1145	354	90	11.4		14.7
05030162	05060162	160	150	875	434	200	14.6	9.5	24.5

*Full-bore in accordance with EN 1555-4

Reduced-bore







Ref GAS	Ref WATER	Outside Ø PE	d1	d2	d3	d4 SDR11	d4 SDR17/17.6	Weight (kg)
05030040	05060040	40	323	150	87	3.7		0.8
05030062		63	380	167	112	5.8		1.1
05030075	05060075	75	389	204	89	6.8		2.2
05030090	05060090	90	389	204	114	8.2	5.4	2.2
05030110	05060110	110	491	252	129	10.0	6.6	4.6
05030125	05060125	125	489	252	131	11.4	7.4	4.8
05030160	05060160	160	735	354	200	14.6	9.5	12.3
05030180	05060180	180	755	354	210	16.4	10.7	13.3
05030200	05060200	200	785	354	225	18.2	11.9	15.0
05030225	05060225	225	815	356	240	20.5	13.4	17.6
05030250	05060250	250	996	434	260	22.7	14.8	36.2

Polyethylene valve

Characteristics

Description	GAS	WATER
Valve name	5030 series	5060 series
Pressure	MOP 10	PN 16
Range	dn20 to dn250	dn20 to dn250
Bore	FB and SB bidirectional	FB and SB bidirectional
Standard	EN 1555-4	EN 12201-04
Certification	BSI, NF APE 136	ACS, NF APE 136
Temperature	-20°C / +40°C	+0° / +60°C
Closing	Clockwise	Clockwise
Square dimensions	50 mm	50 mm
Square colour	Yellow	Blue
Seal	NBR	EPDM
Caps	Yes	Yes
SDR	11, 17 or 17.6	11, 17 or 17.6

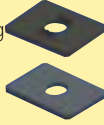
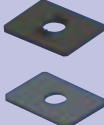
Options

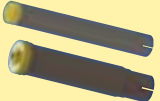
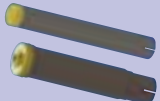
Description	GAS	WATER
Square head dimensions	23 mm 	30 mm (counterclockwise) Up to dn90 
T-saddle extension	90 or 110 mm 	90 or 110 mm 
Baseplate	Rotating or non-rotating clip-on 	Rotating or non-rotating clip-on 
Valve key and extension	50 x 50 mm Resistance up to 150 Nm 	50 x 50 mm Resistance up to 150 Nm 
Extension	Fixed or telescopic 	Fixed or telescopic 

Water PE Kit

The **BANIDES** Water PE Kit contains a factory-welded connection socket on a valve and an electrofusion weldable fitting for connection to a PE water supply network.

This "all-in-one" solution makes it easy to create a connection to a PN16 PE drinking water supply network.

Reference	PE inlet Ø	PE outlet Ø
0063025	63	25
0075025	75	25
0090025	90	25
0110025	110	25
0125025	125	25
0160025	160	25
0180025	180	25
0063032	63	32
0075032	75	32
0090032	90	32
0110032	110	32
0125032	125	32
0160032	160	32
0180032	180	32
0090050	90	50
0110050	110	50
0125050	125	50
0160050	160	50
0180050	180	50



Pressure relief valve

1/4 turn PE valve equipped with purge point devices for:

- Work on the network without cutting off the gas supply
- Bleeding pipes to allow bypassing and/or work to be carried out safely
- Taking pressure readings to detect variations, over-use or under-use of the network or any leaks

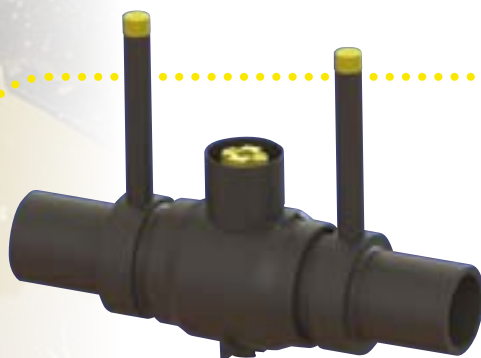

Example of custom development:

Shortened drain
50 mm or 200 mm

PE valves with purge points

PE valve to be electrofusion welded onto 2 PE pipes, fitted with pressure relief devices for draining pipes and taking pressure readings.

End valves are designed to limit or eliminate the flow of gas in a pipeline very quickly, either during routine operations or when a network is in danger.

The composition of the bleed nipples can be adapted to each application:

Examples:

- PE valve dn32
- Brass valve dn25
- Threaded connection for bleed nipple

Purge points equipped with brass valves (GRDF version)

Technical specifications

Maximum operating pressure: 5 bar.

1/4-turn closure with 50 mm square.

Single-purge or dual-purge version.

Telescopic extension (580 to 880 mm).

Thickness SDR17 for $dn \geq 200$.

Drain fitted with 90° brass valves, type E1 and caps with Sphero-Conical Junction (JSC).

Temperature class: -20°C to +40°C

Certification: Complies with GRDF specification SROB 700.

REF DUAL-PURGE	REF SINGLE-PURGE	PE NETWORK Ø
15520063	15510063	63
15520125	15510125	125
15520160	15510160	160
15524200	15514200	200



Purge points equipped with PE valves (Export version)

Technical specifications

Maximum operating pressure: 10 bar.

1/4-turn closure with 50 mm square.

Single-purge or dual-purge version.

Watertight welded extension

Thickness SDR11

Drain fitted with PE valves and 1" threaded end caps on

Temperature class: -20°C to +40°C

REF DUAL-PURGE	REF SINGLE-PURGE	PE NETWORK Ø
J5520063	J5510063	63
J5520091	J5510091	90
J5520125	J5510125	125
J5520164	J5510164	160*

*under development



J5530 valve with sealed protection sleeve

The gas-tightness of **BANIDES** PE ball valves is ensured by one-piece elastomer seals. We recommend using electrofusion welding to connect the PE ball valve to the gas pipe. (NB: butt fusion only if resin compatibility between valve and pipe or fitting). The double-length PE sleeves allow up to 2 welds. The extension is tight and protected against external contamination (dust, etc.)

Product description

PE 5030 quarter-turn ball valve, for gas networks from -20°C to +40°C, fitted with a welded protection extension (on the valve) and an integrated operating extension (upper square 50x50).

Standards

Design in accordance with NF EN 1555-4

Key benefits

- Robust design for a 50-year operating life
- Tight against water, dust, soil, etc.
- The extension protection pipe cannot rotate while the valve is in operation
- Ready for burial
- No maintenance required
- Bidirectional valve. (can be fitted in either direction)
- Low operating torque

List of components

1	Operating square head
2	ball
3	sleeve
4	clips for baseplate
5	traceability data
6	protective pipe for welded extension

Full-bore

Reference	PE Ø	Size	d1	d2	d3	d4 SDR11	d5	Weight (kg)
J5530032	32	25	323	773	87	3.0	710	2.7
J5530050	50	40	456	827	90	4.6	724	4.1
J5530064	63	50	456	827	112	5.8	718	4.1
J5530075*	75	65	389	827	89	6.8	712	4.2
J5530091	90	80	463	876	114	8.2	734	6.0
J5530110*	110	100	491	876	129	10.0	729	6.3
J5530125*	125	125	489	876	131	11.4	721	6.5
J5530162	160	150	875	878	200	14.6	710	30

*Reduced-bore in accordance with EN 1555-4

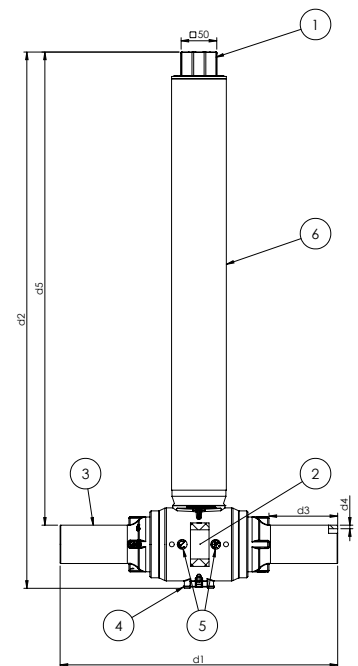

PE valve with branch saddle (RPC)

Electrofusion welded saddle with integrated valve for tapping a PE gas supply network in the ground before the meter



Create a bypass without needing to cut off the gas



Technical specifications

Description	Electrofusion welded saddle with PE valve fitted with a special sleeve for tapping (using a tapping machine)
Certification	Complies with NF 136
Fields of application	GAS network
Types of gas	Natural gas, Manufactured gas, Propane, Propane-air
Operating pressure	Up to 10 bar maximum (MOP 10) in SDR11
Operating temperature	Between -20°C and +40°C
Material	PE 100

- Allows a branch to be made from an existing PE pipe
- Equipped with a PE ball valve with 1/4-turn closure
- Special sleeves for securing the cutting tool (tapping machine)
- Space-saving solution (limits the need for deep excavations)
- Fast, safe installation (less than 2 hours)
- The integrated valve can be used as a mains tap

Technical performance

Application	The RPC Tapping Saddle is designed to create bypasses without interrupting the flow of gas from an existing pipeline
Composition	On one side, the Tapping Saddle has a bypass saddle factory-welded directly to the body of the 1/4 turn valve. On the other side, the special sleeve is machined to accommodate the appropriate cutting tool
Closing	1/4 turn clockwise

PE valve with branch saddle (RPC)

Electrofusion welded saddle with integrated valve for tapping a PE gas supply network in the ground before the meter

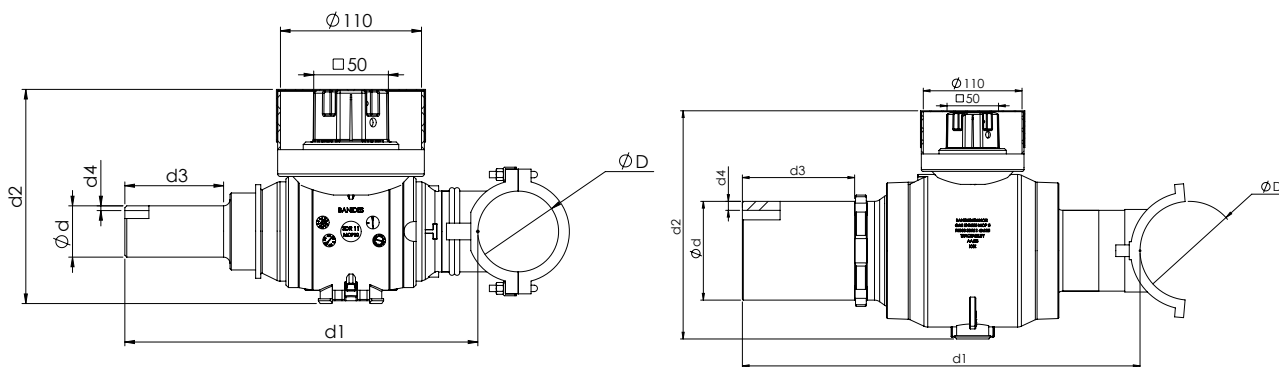
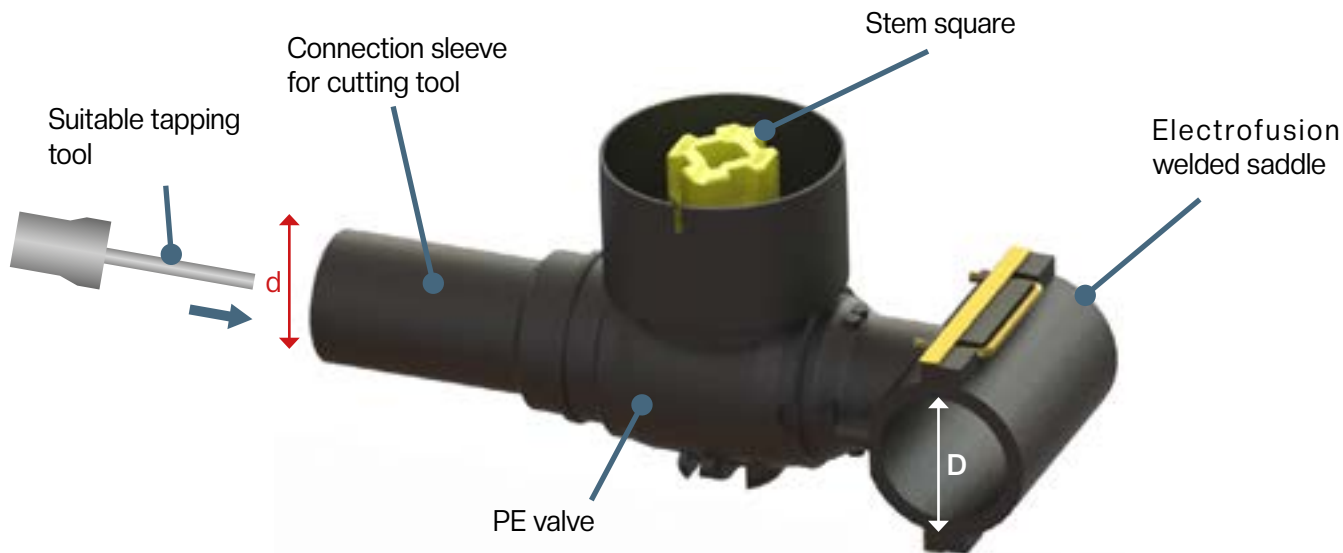

Reference	Main pipe Ø D (inlet)	Connection Ø d (outlet)	Valve/cutting tool connection	Cutting tool Ø	d1	d2	d3	d4
15043040	63	40	Screwing	23	275	167	77	3.7
15044040	110	40	Screwing	23	275	167	77	3.7
15045040	125	40	Screwing	23	275	167	77	3.7
15046040	160	40	Screwing	23	275	167	77	3.7
15043062	63	63	Screwing	39	296	167	101	5.8
15044062	110	63	Screwing	39	296	167	101	5.8
15045062	125	63	Screwing	39	296	167	101	5.8
15046062	160	63	Screwing	39	296	167	101	5.8
15044110	110	110	Fastening onto lugs	67	443	254	125	10
15045110	125	110	Fastening onto lugs	67	443	254	125	10
15046110	160	110	Fastening onto lugs	67	443	254	125	10
15045125	125	125	Fastening onto lugs	67	443	254	125	11.4
15046125	160	125	Fastening onto lugs	67	443	254	125	11.4

PE valve with branch saddle (RPC)

Electrofusion welded saddle with integrated valve for tapping a PE gas supply network in the ground before the meter

Tapping saddles (RPCs) can be used to create bypasses without shutting off supply, using a **BANIDES** PE ball valve as the "lock". The latter is fitted with a T-saddle and can be either:

- usable as a cut-off device and to accommodate traditional valve accessories
- neutralised in cut-off position by adding a cover (supplied) to the T-saddle

As part of the tapping saddle function, the welding ends of the **BANIDES** PE valve are replaced on one side by a factory-welded bypass saddle (rigid saddle or strap) and on the other by a smooth sleeve designed for the tapping machine

Technical performance

- PE 1/4 turn ball valve
- Maximum operating temperature: $-20^{\circ}\text{C}/+40^{\circ}\text{C}$
- Pressure up to 10 bar
- PE 100

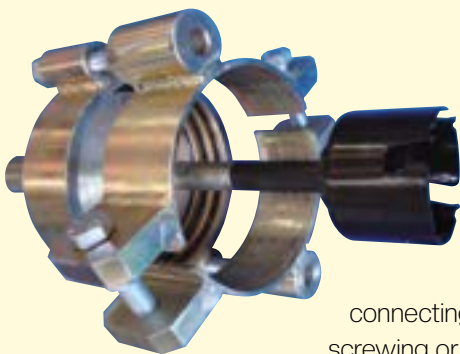
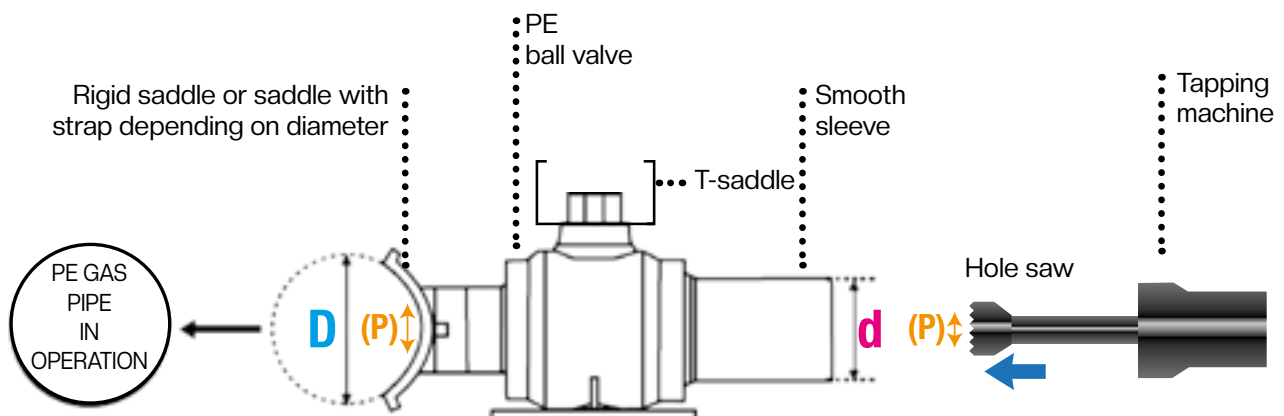

IN CHARGE DRILLING MACHINE

specifically designed for tapping saddles, provided in an aluminium case for transport, adapted to site conditions. Depending on the DN of the valve, there are 2 ways of connecting the tapping machine to the valve: by screwing or by fastening onto lugs. Each type of case includes all the tools required for a range of cutting. The cutting equipment consists of a main body, clamps and a hole saw.





Excess flow valve

Excess flow valve

Two designs compatible with most PE pipes and tapping tee

WHAT IS A RELEASE FOR?

To interrupt the flow of gas downstream of the release in the event of an excessive flow due to a third party or to an incident on the network (hose pulled out, fire, etc.)

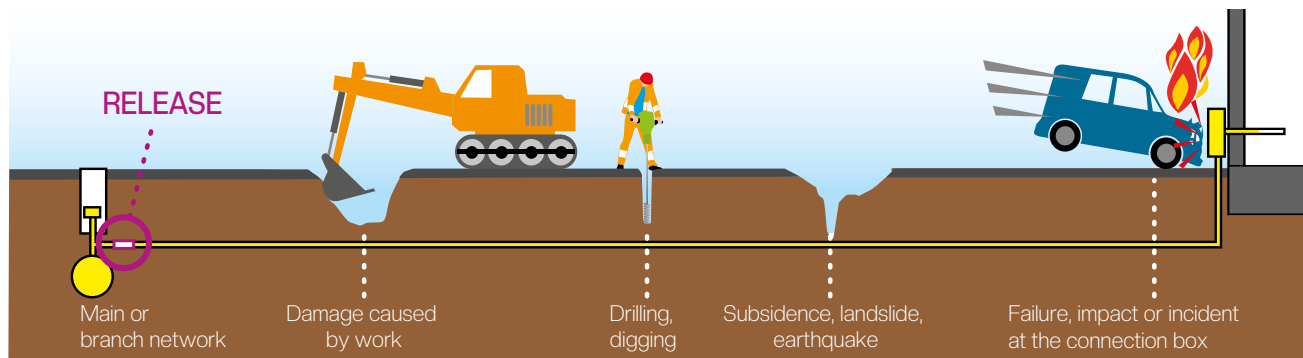

WHY INSTALL A RELEASE FOR EXCESS DOWNSTREAM FLOW IN A CONNECTION?

- To control gas leak incidents
- To ensure safe working conditions for operatives working on a medium-pressure network (0.5 to 5 bar)
- To avoid emergencies

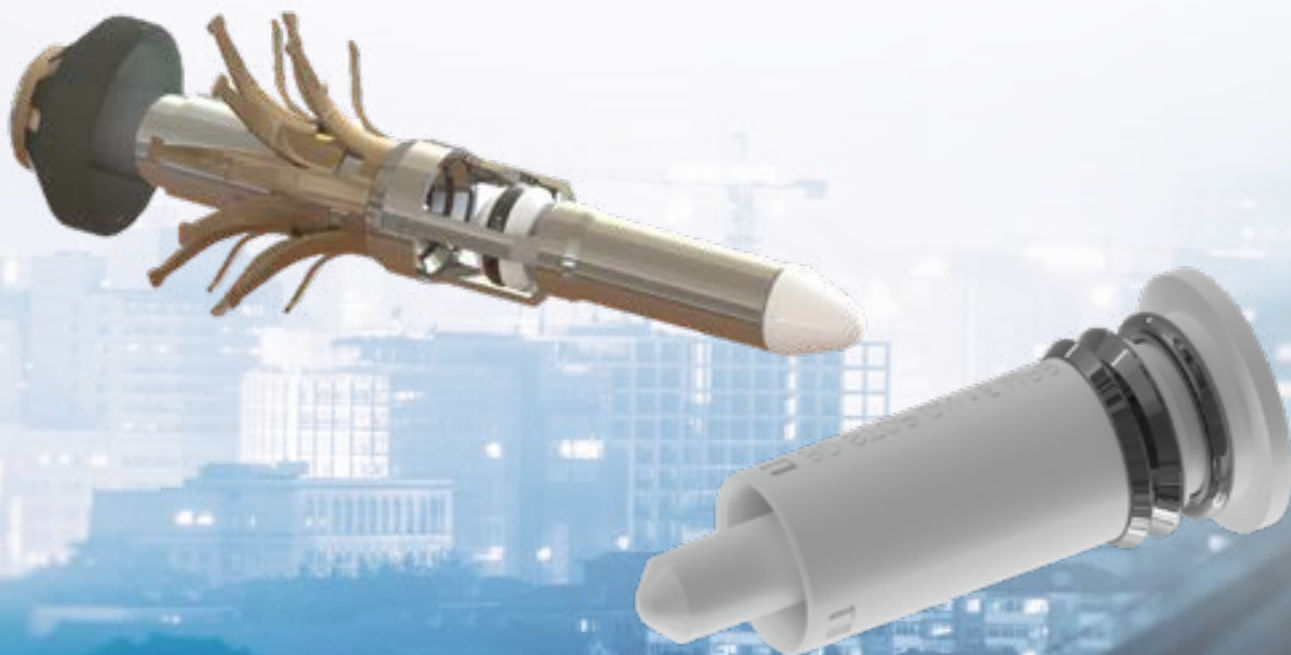

BDSTOP

THE SOLUTION FOR THE SAFETY OF NEW CONNECTIONS



2 models available

• **"Mechanical RESET"**: by injecting air through a test port on a service tap to equalise the upstream and downstream pressures (tight model, requires the presence of a service tap fitted with a test port)

• **"CALIBRATED LEAK"**: automatic reset without the need for intervention by a third party (does not require the presence of a service tap fitted with a test port after network repairs)

- Underground installation with digging or excavation

3 product configurations:

- BDSTOP alone
- MBDI®: PE sleeve fitted with a BDSTOP
- PBDI®: PE connection socket fitted with a BDSTOP

Technical performance

- Type of Gas: Natural gas, Manufactured gas, Propane network and Propane-air
- Materials: cartridge and internal parts made from polyacetal, stainless steel spring, NBR seals.
- Operating pressure: 0.5 to 5 bar
- Operating temperature: -20°C / +45°C
- Available diameters: PE20 / PE25 / PE32
- Mounted at approximately 45° to the horizontal

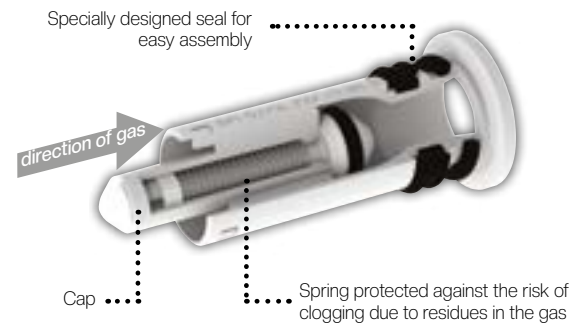

INSTALLATION AND OPERATION OF THE BDSTOP

1



MBDI®: Connection Sleeve with Integrated Release

Sleeve fitted with BDSTOP for use with steel/PE connections via a mechanically clamped transition fitting

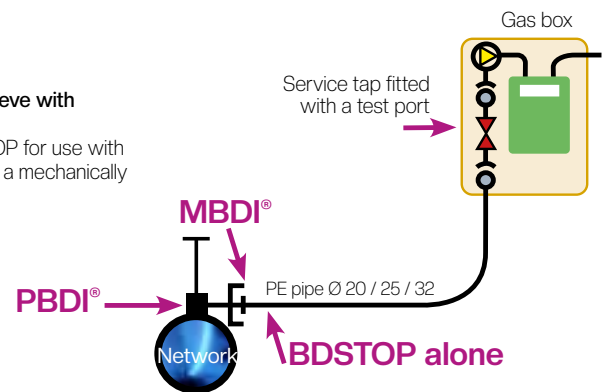

PBDI®: Connection Socket with Integrated Release

PE (SRD11) socket fitted with a BDSTOP in the socket outlet barrel

2 BDSTOP release open

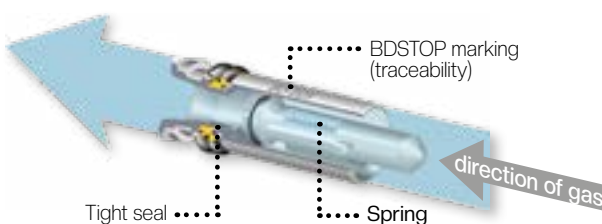

3 BDSTOP release closed

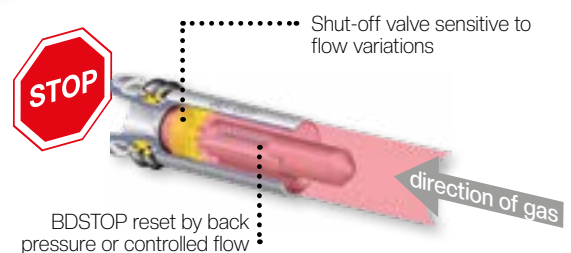

DPBE

THE SOLUTION FOR ENSURING THE SAFETY OF EXISTING CONNECTIONS



2 models available

- **"Mechanical RESET"**: by injecting air through a test port on a service tap to equalise the upstream and downstream pressures (tight model)
- **"CALIBRATED LEAK"**: automatic reset without the need for third-party intervention after network repairs
- Above-ground installation with no digging or excavation (through the box valve)
- Installation without interrupting the network's gas supply
- Introduction into the pipeline from the service connection

Technical performance

- Type of Gas: Natural gas, Manufactured gas, Propane network and Propane-air
- Materials: brass, polyacetal, stainless steel, NBR seals.
- Operating pressure: 500 mbar to 5 bar
- Operating temperature: -20°C / +45°C
- Available diameters: PE 20 / 25 / 32
- Mounted at approximately 45° to the horizontal

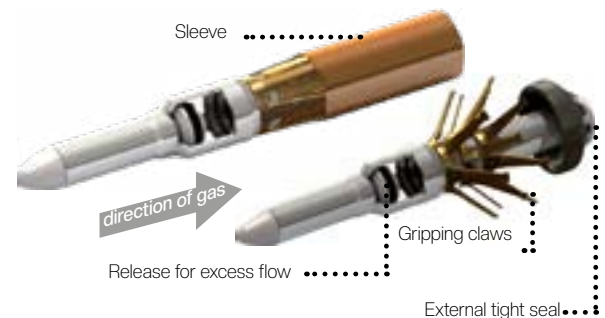

*DPBE: Excess flow valve for existing connections under licence from GRT Gaz

INSTALLATION AND OPERATION OF THE DPBE

Insertion into the pipe in operation through the service connection tap using special tools

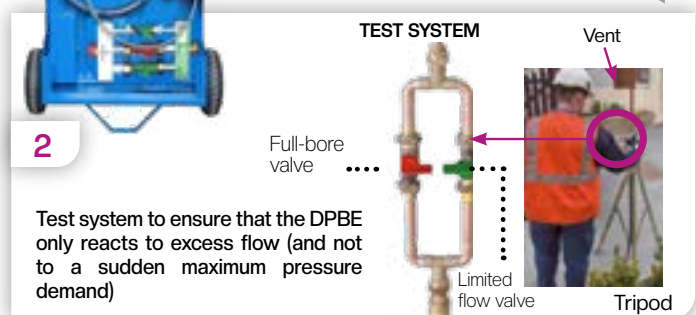
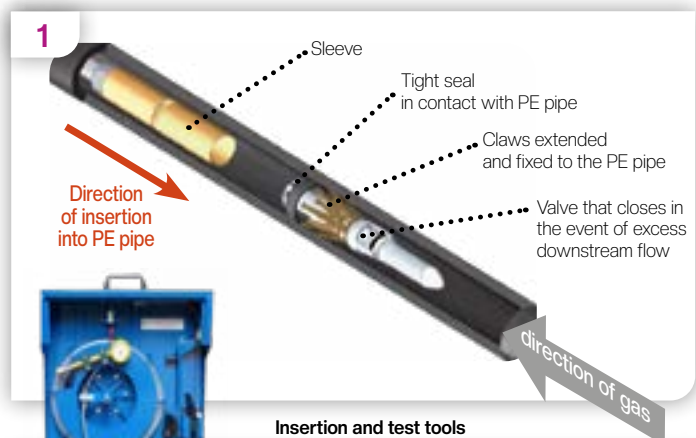
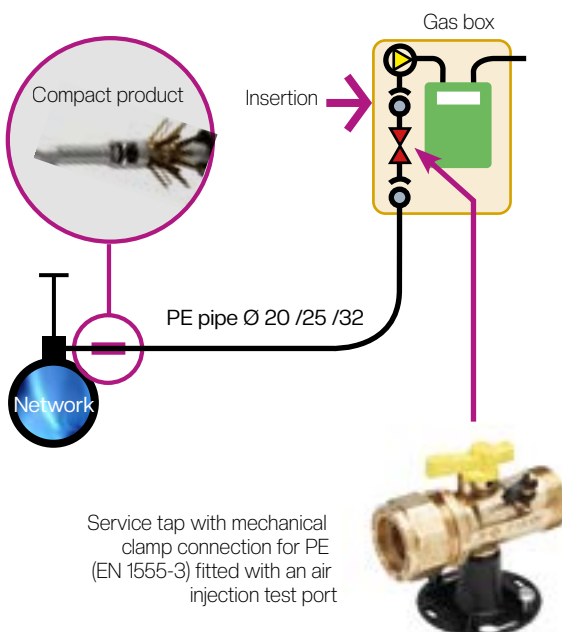

Test system to ensure that the DPBE only reacts to excess flow (and not to a sudden maximum pressure demand)

Actual product may differ from images



Connection and transition



Connection and transition

PERRSO® PE/PE QUICK CONNECTOR



Connect or cap a PE gas pipe with a single click

- Quick connection in less than 2 minutes
- Audible "click" to indicate that the device is engaged
- Installation requires no special preparation of the PE pipe or fitting (no chamfering necessary)
- Installation without special tools = cost savings
- Non-removable connection system
- Simple, economical and effective alternative to electrofusion welding or mechanical clamp connections
- Product benefits: separate "sealing" and "connection" functions

COMPARISON	PERRSO SYSTEM®	MECHANICAL SYSTEM	ELECTROFUSION WELDING SYSTEM
	 2 min	 +/-5 min	 35 min
ASSEMBLY PRINCIPLE	Manual assembly	Mechanical clamping	Fusion welding of PE pipe
EQUIPMENT REQUIRED	None. ECONOMICAL!	Flat spanner and mallet	Generator, electrofusion welder and positioner
TRAINING	None. INTUITIVE!	Reading the assembly instructions	Welding qualification required
FINAL INSPECTION	Manual check in less than 10 seconds!	Protection with anti-corrosion adhesive tape	Tightness check

PERRSO® connector

Main characteristics

- Single-use, non-removable connection and/or sealing system for PE gas networks
- Gas network
- Natural gas, Manufactured gas, Propane, Propane-air
- Up to 5 bar
- from -20°C to +45°C
- PE 20 and PE 32

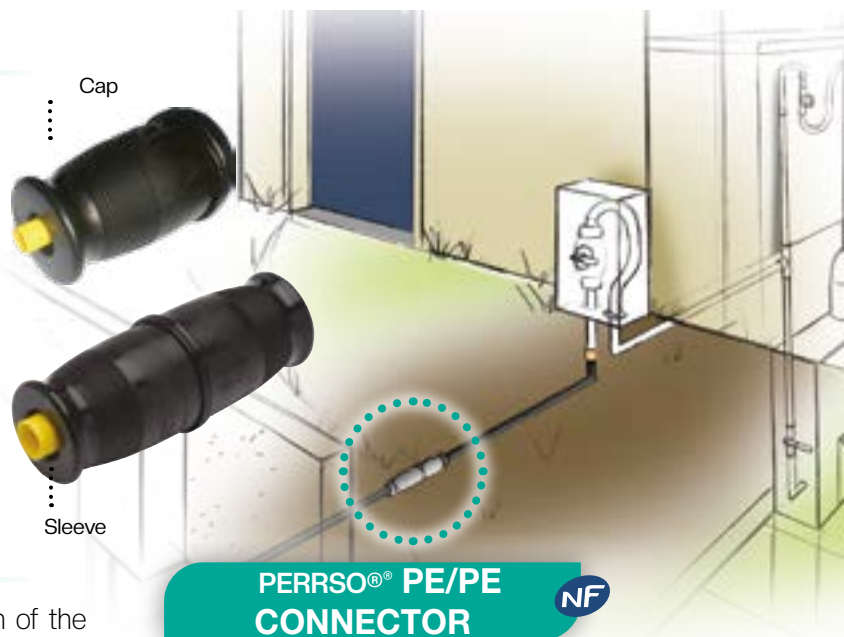

Technical performance

The "click" that you hear signals the end of insertion of the tube and guarantees that it clicks into place and remains tight
 Seals are protected against sharp pipe edges and PE chips
 As the claws are located after the seals in the direction of insertion, the tube cannot be damaged by the claws
 The PERRSO® casing is made of PE 100.
 Stainless steel spring

PERRSO® PE/PE CONNECTOR

Certification

Certified EN 1555-3 and ISO 17885

	Ref	Dimension	PE thickness	Length in mm	Max Ø in mm	Weight in g	
	PERRSO® Cap	E684015	PE 20	3	107 mm	62.3 mm	205 g
	E684025	PE 32	3	114 mm	77.3 mm	300 g	
	PERRSO® Sleeve	E682415	PE 20	3	186 mm	62.3 mm	350 g
	E682425	PE 32	3	199 mm	77.3 mm	520 g	

A quick, easy, reliable and cost-effective connection in 4 simple steps



1 Cutting the tube

Cut to length

There is no need to prepare the end of the tube (no chamfering required).



2 Cleaning the tube

Clean the tube with a clean cloth.

Check at least 15 cm of the end of the tube, checking for dents and scratches.



3 Fitting

Fit together the tube and pipe until you hear the "CLICK" of the connection system engaging.



4 Assembly check

Pull hard on the PE pipes to check that they are firmly in place.

Connection and transition

To make a PE/metal transition allowing entry into a building:

In accordance with regulations, a polyethylene pipe must be connected to a copper or steel metal pipe approximately one metre before it enters the wall.

PE/METAL CONNECTOR

FOR WELDING TO STEEL PIPES AND FOR ELECTROFUSION WELDING ON THE PE SIDE

Connecting a PE pipe to a steel pipe

Length of PE sleeve allowing a second electrofusion weld if required

Length of steel sleeve designed to prevent heat transmission during welding

Technical Performance

- Maximum operating pressure: 5 bar
- Connection of the PE sleeve to the PE pipe using an electrofusion-weldable sleeve
- Steel tube protected by anti-corrosion treatment
- NF APE certified
- Complies with NF EN 1555-3
- PE 100

* Available in MOP 5 bar and MOP 10 bar



SIZE	INLET	OUTLET
25	PE 32	ST 33.7
32	PE 40	ST 42.4
50*	PE 63	ST 60.3
80	PE 90	ST 88.9
80	PE 110	ST 114.3
100*	PE 125	ST 114.3
150*	PE 150	ST 168.3
200	PE 200	ST 219.1

TO BE WELDED TO STEEL PIPES AND MECHANICALLY CLAMPED ON THE PE SIDE

Connection by mechanical assembly, without special tools, of a PE pipe to a steel welding socket

Tightening without a torque wrench

Technical Performance

- Maximum operating pressure: 5 bar
- Tightening to stop without a torque wrench for PE 20, 32, 40 and 63 pipes
- Flange clamp for PE 90, 110 and 125 pipes
- NF APE certified
- Complies with NF EN 1555-3



*Flanged version

SIZE	INLET	OUTLET
15	PE 20	ST 21.3
25	PE 32	ST 33.7
32	PE 40	ST 42.4
50	PE 63	ST 60.3
80*	PE 90	ST 88.9
100*	PE 110	ST 114.3
125*	PE 125	ST 114.3

TO BE WELDED TO COPPER PIPES AND MECHANICALLY CLAMPED ON THE PE SIDE

Connection by mechanical assembly, without special tools, of a PE pipe to a copper welding socket

Tightening without a torque wrench

Technical Performance

- Maximum operating pressure: 5 bar
- Tightening to stop
- NF APE certified
- Complies with NF EN 1555-3



SIZE	INLET	OUTLET
15	PE 20	CU 16
15	PE 20	CU 18
20	PE 32	CU 22
25	PE 32	CU 28
32	PE 40	CU 35
32	PE 40	CU 42
50	PE 63	CU 54



Brass valve

Brass valve

Why choose our brass valves?

The expertise of **BANIDES** in the field of gas since 1928

- Mastery of the design of products and industrial processes
- Automatic production line and leak test on 100% of products
- Valves designed and manufactured exclusively for use with natural gas, propane gas and propane-air

Materials vigilance

- Brass CW 617N or CW 614N in accordance with EN 12165:
 - Superior quality guaranteed for 50 years: very low levels of impurities
 - Thickness to avoid any porosity, as the gas molecules are very small

Standards vigilance

- The **BANIDES** valve complies with European Standard EN 331 "Manually operated ball valves and closed bottom taper plug valves for gas installations for buildings"
- BSPP/Parallel gas threads in accordance with ISO 228 "Pipe threads where pressure-tight joints are not made on the threads"

Experience with French gas policies

• Double male valve:

The valve is connected to the pipes by two-piece connectors with captive swivel nuts, making them easy to install and, above all, easy to dismantle

• Specific gas tightness:

- Flat Gasket for Low Pressure:
(Gas Flat Gasket (JPG) and Meter Flat Gasket (JPC))
- Sphero-Conical Connection for Medium Pressure:
Metal/metal sealing

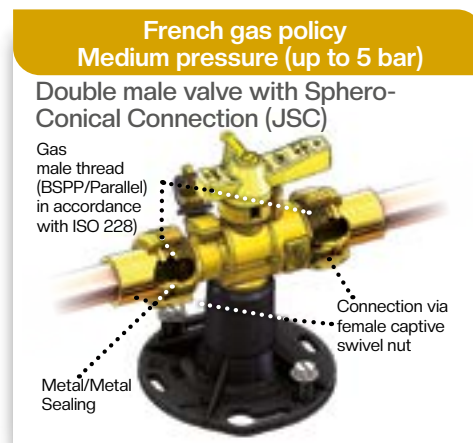

French gas policy Low pressure (up to 500 mbar)

Double male valve with Gas Flat Gasket (JPG)

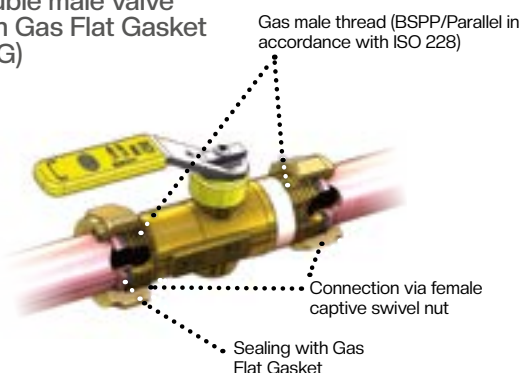

Double male valve with Meter Flat Gasket (JPC)

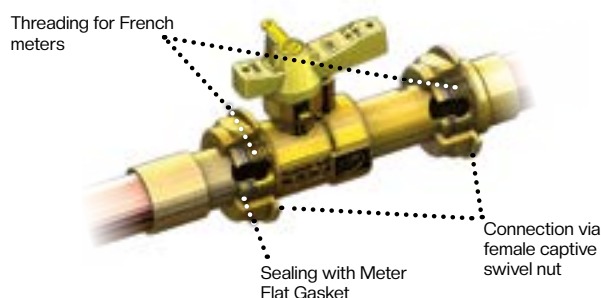

CAUTION: observe the tightening torques

Brass valve

SAFETY VALVE



- Medium pressure 1/4 turn valve for pipes up to 5 bar pressure
- Compact, one-piece, maintenance-free valve body with two flats for secure clamping
- 3 sizes available (15, 25, 32) with various options: baseplate, locking system, test port, plastic or metal lever or square head
- 3 types of inlet available: female, male with Sphero-Conical Connection or mechanical clamp connection for PE
- Male outlet with Sphero-Conical Connection (cone compliant with standard NF E 29-536)
- Valve compliant with EN 331 and certified to NF ROB GAZ and NF APE for PE inlet connection

FOR EMERGENCY SHUT-OFFS THE "ONE-TOUCH" VALVE



The "one-touch" push-button valve: once the gas supply has been cut off following an incident, it can only be reactivated using a special key and by an authorised person



- Maximum operating pressure 5 bar
- Double male version with Sphero-Conical Connections
- Version with mechanically clamped PE inlet and male Sphero-Conical Connections outlet
- 2 sizes: 15, 25
- Temperature class: - 20°C / + 60°C
- Complies with NF EN 331, NF E 29 142; NF ROB-GAZ certified

Brass valve

Different types of levers available:

Plastic lever



Metal lever



Marking on request

14 mm square head, pin lockable or blockable



Different lever locking systems: manual or automatic

Locking pin



Locking screw + key



Spring-loaded lock pin + key



Inlets

3 types of inlet available

Female



Male BSPP/Parallel to Sphero-Conical Connection (G 3/4" to G 1 1/2")



Mechanical clamp connection for PE from 20 to 40 mm (EN 1555-3)



Body

3 body sizes 15/25/32



Option: test port (fitted with a cap) and attachment

Outlet

Male outlet with Sphero-Conical connection (G 3/4", G 1 1/4, G 1 1/2)

Option plastic valve baseplate for mounting in box, 4 heights available:

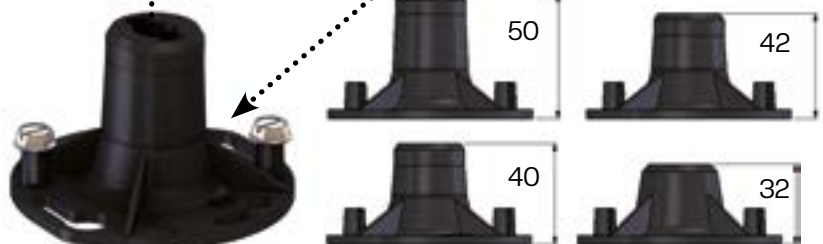

Brass valve

METER VALVE

- Low Pressure 1/4 turn valve for pipes up to 500 mbar pressure
- Compact, one-piece, maintenance-free valve body with two flats for secure clamping
- 3 sizes available (20, 32, 50) with various options: locking system, plastic or metal lever or square head
- Male inlet with Meter Flat Gasket (JPC)
- Outlet with female captive swivel nut and Meter Flat Gasket (JPC) to screw onto meter
- Captive swivel nut with sealing hole
- Valve compliant with EN 331 and certified to NF ROB GAZ

Different types of levers available:

Plastic lever

Metal lever

14 mm square head, pin lockable or blockable



3 possible configurations

Inlet	Body size	Outlet
Male JPC DN20	20	Female (swivel nut) JPC DN20
Male JPC DN32	32	Female (swivel nut) JPC DN32
Male JPC DN50	50	Female (swivel nut) JPC DN50

Different lever locking systems: manual or automatic

Locking pin



Locking screw + key



Spring-loaded lock pin + key



APPLIANCE CONTROL VALVE: Heating system valve

1/4 turn valve

Body with 2 flats for secure clamping

Ergonomic lever (metal and plastic)

Size 15 to 50 adaptable to all types of installation (residential, commercial and tertiary)

Technical Performance

- Maximum operating pressure: 500 mbar
- Double male valve with Gas Flat Gasket
- Temperature class: - 20°C / + 60°C
- NF ROB GAZ certified
- Complies with NF EN 331



Ref 42013015

Brass valve

VALVE FOR IN HOUSE INSTALLATION

- Low Pressure 1/4 turn valve for pipes up to 500 mbar pressure
- Compact, one-piece valve body requiring no maintenance
- Various sizes available to suit the size of the installation (12 to 50) with different options:
metal or plastic lever
- Body with or without feet depending on installation configuration
- Valve compliant with EN 331 and NF ROB GAZ



INTEGRATED AUTOMATIC SHUT-OFF VALVE

Automatic cut-off of the gas supply in the event of excess downstream flow (at the valve outlet) caused by the flexible hose being pulled out of the gas cooker (or appliance). Reset by simply closing the valve.
Mounting direction indicated by an arrow on the body.

Compulsory in France since 1997 for the connection of domestic cooking appliances!



Double male
Integrated automatic
shut-off valve
Ref E295511

Technical Performance

- Maximum operating pressure: 37 mbar
- Size 12
- Double male valve G 1/2", with integrated automatic shut-off valve
- Version with cap (fitted with 1 seal) and clip available
- Temperature class: -5° / +60°C
- Complies with EN 331 and NF E 29-140

REMEMBER PERSONAL SAFETY AND THE INTEGRATED AUTOMATIC SHUT-OFF VALVE (triggered by excess downstream flow)

The integrated shut-off mechanism prevents the spread of gas by interrupting the flow of gas. It is located in the body of the gas valve.
NB: upstream pressure < 50 mbar

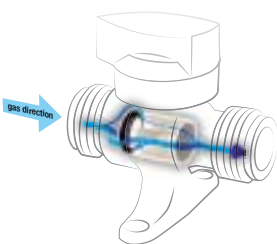

Normal operation,
Continuous gas flow

Incident: e.g. gas cooker flexible hose pulled out downstream of the valve

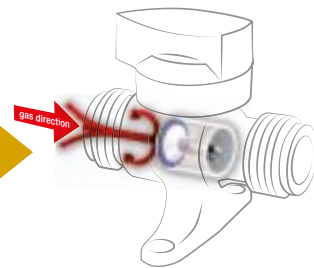

Automatic cut-off of gas supply due to
excess downstream flow

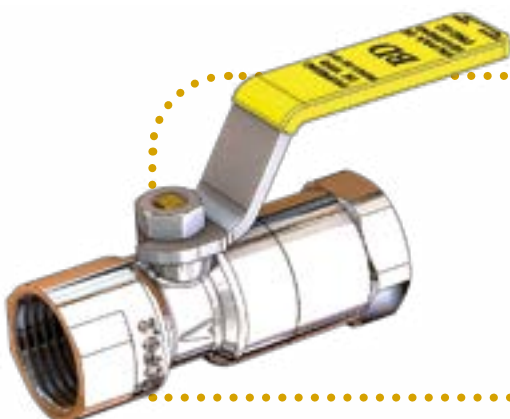

Example of custom development:

Size 12 double female G 1/2" valve (BDPP/Parallel thread in accordance with ISO 28 / EN 10226) with integrated automatic shut-off for installation with 6.25% tapered male pipe (BSPT Tapered thread in accordance with ISO 7)

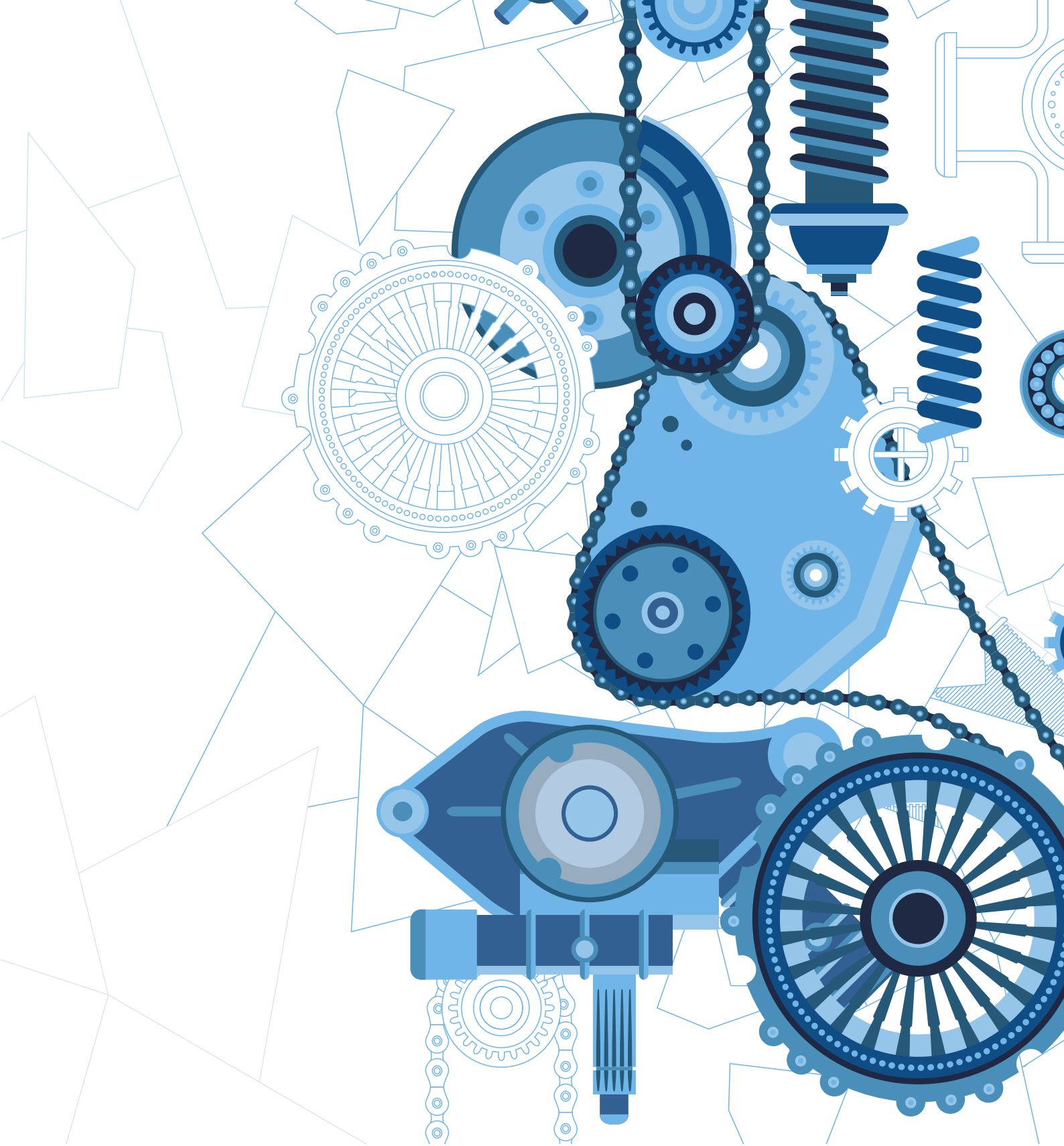

Technical manual

Technical Manual

PRESSURE CONVERSION TABLE

bar	psi	psi	bar
0.1	1.45	1	0.068
0.5	7.25	2	0.137
0.75	10.88	3	0.206
1	14.5	4	0.275
1.5	21.75	5	0.344
1.75	25.38	10	0.689
2	29	15	1.034
2.5	36.25	20	1.379
2.75	39.88	25	1.723
3	43.5	30	2.068
3.5	50.75	35	2.413
4	58	40	2.748
4.5	65.25	45	3.102
5	72.5	50	3.447
5.5	79.75	55	3.792
6	87	60	4.137
6.5	94.25	65	4.481
7	101.5	70	4.826
7.5	108.75	75	5.171
8	116	80	5.516
8.5	123.25	85	5.86
9	130.5	90	6.205
9.5	137.75	95	6.55
10	145	100	6.895

p.s.i.: "pounds per square inch"

1 p.s.i. = 6,894.76 Pascals = 0.069 bar.

1 bar = 14.5 psi = 10⁵ Pascals

PIPE CORRESPONDENCE

Designation of PE pipes

SIZE DN	PE EXT. Ø	IN INCHES	GAS (metric)	STEEL ext. Ø x Thickness (mm)	COPPER ext. Ø x Thickness (mm)
15	20	1/2"	15/21	21.3 (x2.3)	12 or 14 (x1)
20	25	3/4"	20/27	26.9 (x2.3)	22 (x1)
25	32	1"	26/34	33.7 (x2.3)	28 (x1)
32	40	1"1/4	33/42	42.4 (x2.6)	35 (x1)
40	50	1"1/2	40/49	48.3 (x2.6)	42 (x1)
50	63	2"	50/60	60.3 (x2.9)	54 (x1)
65	75	2"1/2	66/76	76.1 (x2.9)	-
80	90	3"	80/90	88.9 (x3.2)	-
100	110	4"	102/104	114.3 (x3.6)	-
125	125	5"	127/140	139.7 (x4)	-
150	160	6"	-	168.3 (x4.5)	-
175	180	-	-	193.7 (x5.6)	-
200	200	8"	-	219.1 (x6.3)	-
225	225	-	-	-	-
250	250	10"	-	273 (x6.3)	-
300	315	12"	-	323.9 (x7.1)	-

Technical Manual

THREADING AND SEALING

DEFINITIONS

- **Screw connection;** Mechanical connection by thread and sealing by gasket, at metal/metal connexion or in the thread (with the addition of sealing tape)
- **Differences between BSPP, BSPT and NPT**
Pressure network connection systems use different methods to ensure tightness, which vary according to country, pipe size and environment.
For example, BSP connections are commonly used in gas distribution, whereas NPT connections are preferred in the oil industry.

1 - CYLINDRICAL GAS THREAD

BSPP (British Standard Pipe Parallel) thread connection in accordance with ISO 228

- Very popular in Europe, Asia, Australia, New Zealand and South Africa
- Also known as "Whitworth" threads or "Gas" threads (e.g. G 1/2", G 3/4", G 1" etc.)
- Requires the use of a seal sandwiched between the face of the male fitting and the shoulder of the female fitting.

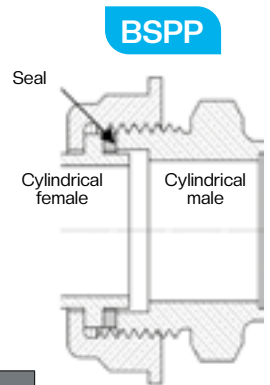

Dimensions of the most common BSPP threads

Designation	3/8"	1/2"	3/4"	1"	1 1/4"	1 1/2"	2"	2 1/4"	2 1/2"	3"	4"
Metric designation	12-17	15-21	20-27	26-34	33-42	40-49	50-60	60-70	66-76	80-90	102-114
Outside Ø (mm)	16.662	20.955	26.441	33.249	41.91	47.803	59.614	65.71	75.184	87.884	113.03
Threads/inch	19	14	14	11	11	11	11	11	11	11	11

*NB: Always observe the tightening torque

2 - TAPERED THREAD

BSPT (British Standard Pipe Tapered) thread connection in accordance with ISO 7 or EN 10226

- 6.25% tapered thread: 55° thread apex angle (see drawings)
- Tape (PTFE type) essential for sealing the screw connection
- Not to be confused with NPT threading (very similar visually, especially in 1/2" and 3/4")

BSPT

The truncations at the bottom and top of the thread **are rounded**

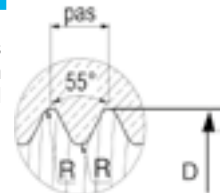

NPT

The truncations at the bottom and top of the thread **are flat**

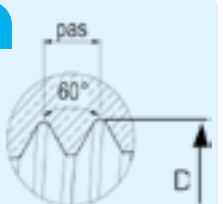

NPT (National Pipe Thread) connection

- The most popular thread-sealed connection system in the USA and Canada
- Tape (PTFE type) essential to ensure the seal

PLEASE NOTE: If you manage to screw an NPT male fitting into a BSP female fitting, this does not mean they are compatible BECAUSE THE SEAL WILL NOT BE GUARANTEED.
The only possible combination is: NPT Tapered female (ASME B 1.20) and NPT Tapered male (ASME B 1.20)

3 - CYLINDRICAL THREAD FOR FRENCH METERS

- Connection system sealed using Meter Flat Gasket (GrDF MFIT 0-01 specifications)

European meter designation	G1.6	G2.5	G4	G6	G10	G16	G25	G40	G65
Size	20	20	20	32	32	50	50	80	80
Former designation	6/20	6/20	6/20	10/32	16/32	25/50	40/50	65/80	100/80
Flow rate m³/h	2.5	4	6	10	16	25	40	65	100
Centre-to-centre	110	110	110	250	250	335	335	430	500

Technical Manual

COMPATIBILITY OF GAS THREADS

Internal Female Thread

Male / External thread

	NPT	BSPP	BSPT
NPT	☺	☹	☹
BSPP	☹	☺ ⚠	☺
BSPT	☹	☹	☺

⚠ *Tightness not ensured in the thread but by seal or sphero-conical metal/metal connection*

1 - ASSEMBLY WITHOUT SEALING IN THE THREAD

BSPP
Cylindrical female

in accordance with ISO 228

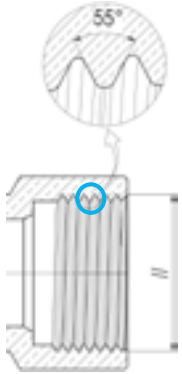

BSPP
Cylindrical male

in accordance with ISO 228

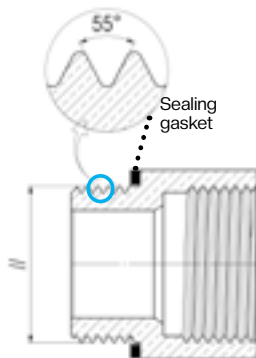

French gas policy
(p. 28)

50 YEARS
OF EXPERIENCE

WITHOUT SEALING IN THE THREAD
With seal using Flat Gasket
(Low Pressure up to 500 mbar)

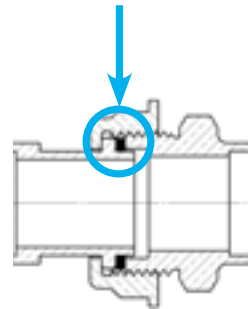

WITHOUT SEALING IN THE THREAD
With metal/metal seal with sphero-conical connection
(Medium Pressure up to 5 bar)

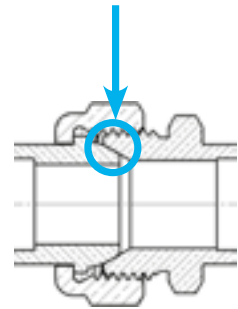

2 - ASSEMBLY WITH THREAD SEAL (and addition of PTFE-type sealing tape)

BSPP
Cylindrical female

former name: ISO 7 / Rp 1/2"

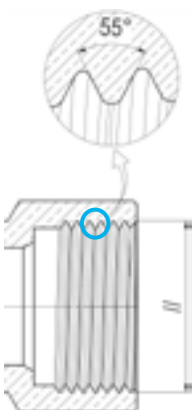

BSPT
Tapered male 6.25%

former name: ISO 7 / R 1/2"

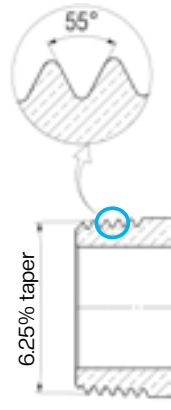

BSPT
Tapered female 6.25%

former name: ISO 7 / Rc 1/2"

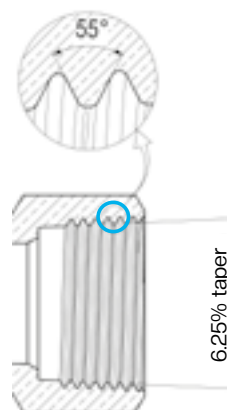

BSPT
Tapered male 6.25%

former name: ISO 7 / R 1/2"

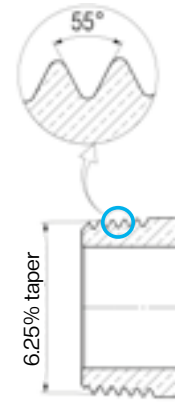

SEALS

Materials

The flat gasket seals used for gas comply with NF E29-533

Two different qualities (Interchangeable seals)

1. Material **SYNTHETIC FIBRE**

(Synthetic aramid fibre + Elastomer binder (e.g. NBR))

Range of use: -20°C / +60°C

Assembly without greasy products or other materials;

Compliance with tightening torque (see tables below)

2. **ELASTOMER plastic material**

(Material in accordance with NF EN 549 Class A2.H3 (e.g. NBR or VITON))

Hardness between 80 and 90 IRHD

Range of use: -20°C / +60°C

Assembly without greasy products or other materials;

Compliance with tightening torques (see tables below)

Tightening torque for seals

There are often problems with tightening torque and crushing of seals.

Joints must work with a certain degree of elasticity: excessive or insufficient tightening torque can cause joints to lose their elasticity or suffer permanent deformation.

CONNECTION AND SEALING GASKET SEALS

Meter Flat gasket (JPC) Reference standard: NF E 29-533



Dimensions and nominal tightening torque of hard Meter Flat Gaskets made of aramid (synthetic fibre)

DN	Inside Ø (mm)	Thickness (mm)	Outside Ø (mm)	Nominal tightening torque (Nm)
20	22.6	2	27.5	30
32	34.2	2	40	50
40	47.2	2	54	100
50	54.2	2	60	120

Dimensions and nominal tightening torque of flexible Meter Flat Gaskets made of elastomer

DN	Inside Ø (mm)	Thickness (mm)	Outside Ø (mm)	Nominal tightening torque (Nm)
20	21.4	2.5	26.3	25
32	33	2.5	38.8	30
40	46	2.5	52.8	40
50	53	2.5	58.8	50

Gas Flat Gasket (JPG) Reference standards: NF E 29-533



Dimensions and nominal tightening torque of hard Gas Flat Gaskets made of aramid (synthetic fibre)

DN	Inside Ø (mm)	Thickness (mm)	Outside Ø (mm)	Nominal tightening torque (Nm)
12	12.4	2	18.2	30
15	18.4	2	23.8	30
20	22.4	2	30	40
25	30.4	2	38.5	60
25 special	26.1	2	30	30
32	38.5	2	44.5	70
40	45.5	2	52.5	100
50	53.5	2	59	120

Dimensions and nominal tightening torque of flexible Gas Flat Gaskets made of elastomer

DN	Inside Ø (mm)	Thickness (mm)	Outside Ø (mm)	Nominal tightening torque (Nm)
25	29.4	2.5	37.5	25
25 special	25.1	2.5	29	25
50	52.5	2.5	65	50

Flange Gasket (JPB) Reference standards: NF E 29-533 and NF EN 1514-1

Dimensions and nominal tightening torque for hard seals made of aramid (synthetic fibre) PN 10

DN	Inside Ø (mm)	Thickness (mm)	Outside Ø (mm)	Nominal tightening torque (Nm)
15	22	2	51	30
25	34	2	71	60
32	43	2	82	80
40	49	2	92	100
50	61	2	107	120
65	77	2	127	180

DN	Inside Ø (mm)	Thickness (mm)	Outside Ø (mm)	Nominal tightening torque (Nm)
80	89	2	142	100
100	115	2	162	150
150	169	2	218	240
200	220	2	273	280
250	273	2	328	300
300	324	2	378	340

METAL-TO-METAL SEALING

Sphero-Conical Connection (JSC) Reference standards: NF E 29-536



Nominal tightening torque for Sphero-Conical Connections

DN	Tightening torque (Nm)
12	25
15	40
20	50
25	60
32	80
40	110
50	140

Particular Characteristics of Steel Piping 6.25% Tapered Male Connections

In the case of steel pipes, threaded joints are permitted for connections to valves and pipe fittings with threaded ends. Sealing is achieved in the thread; sealing materials (sealing compound) must be used. It is forbidden to use oakum or sealing tapes.

Notes



A series of horizontal grey lines for writing, with a vertical red margin line on the left side.

BANIDES

the world of Gas and Water



Tel. +33 (0)2 35 86 05 00
Route d'Eu - CS 40043
76470 LE TRÉPORT FRANCE
export@banides.fr

www.banides.fr